

Donna The Buffalo - Stage SetUp 2007

#	Instrument	FOH Ch	Mon Ch	Mic/DI	Stand/Boom	We Supply	+48v	Monitor Note	Changes
1	Kick Drum			Beta 52	Short Boom	Mic		Drum Mon Only	
2	Snare Top			SM 57	Short Boom	-		X	
3	Snare Bottom			SM 57	Short Boom	-		X	
4	High Hat			AKG C-451	Short Boom	-	+	Drum Mon Only	
5	Rack Tom			SENN e604	Clip	-		Drum Mon Only	
6	Floor Tom 1			SENN e604	Clip	-		Drum Mon Only	
7	Floor Tom 2			SENN e604	Clip	-		Drum Mon Only	
8	Over Head L			AKG C-451	Tall Boom	-	+	X	
9	Over Head R			AKG C-451	Tall Boom	-	+	X	
10	Bass D.I.			From Amp	XLR	D.I.		X	
11	Bass Mic			MD 421	Short Boom	-		X	
12	Leslie Lo			Beta 52	Short Boom	-		Bill	
13	Leslie Hi L			SM 57	Tall Boom	-		Bill	
14	Leslie Hi R			SM 57	Tall Boom	-		Bill	
15	Keyboard - Twin			SM 57	Tall Boom	-		Bill	
16	Digital Piano L			Radial JDI	XLR	D.I.		Kathy, Jeb, Bill	
17	Digital Piano R			Radial JDI	XLR	D.I.		Kathy, Jeb, Bill	
18	Jeb's E. GTR			SENN e609	Hang	Mic		Bill	
19	Fiddle DI			From Amp	XLR	D.I.		X	
20	Fiddle Mic			SENN e609	LP Claw	Mic & Claw		X	
21	Accordion 1			Radial J48	XLR	D.I.	+	Tara, Jeb	
22	Accordion 2			Radial J48	XLR	D.I.	+	Tara, Jeb	
23	Acoustic GTR 1			Pendulum	XLR	D.I.		Tara, Jeb	
24	Rub Board			SM 57	Tall Boom	-		Tara	
25	Kathy Voc			Beta 57	Tall Boom	Mic		Kathy	
26	Jeb Voc			SM 58	Straight Stand	Mic		Jeb, Bill	
27	Tara Voc			Beta 58	Tall Boom	Mic		Tara	

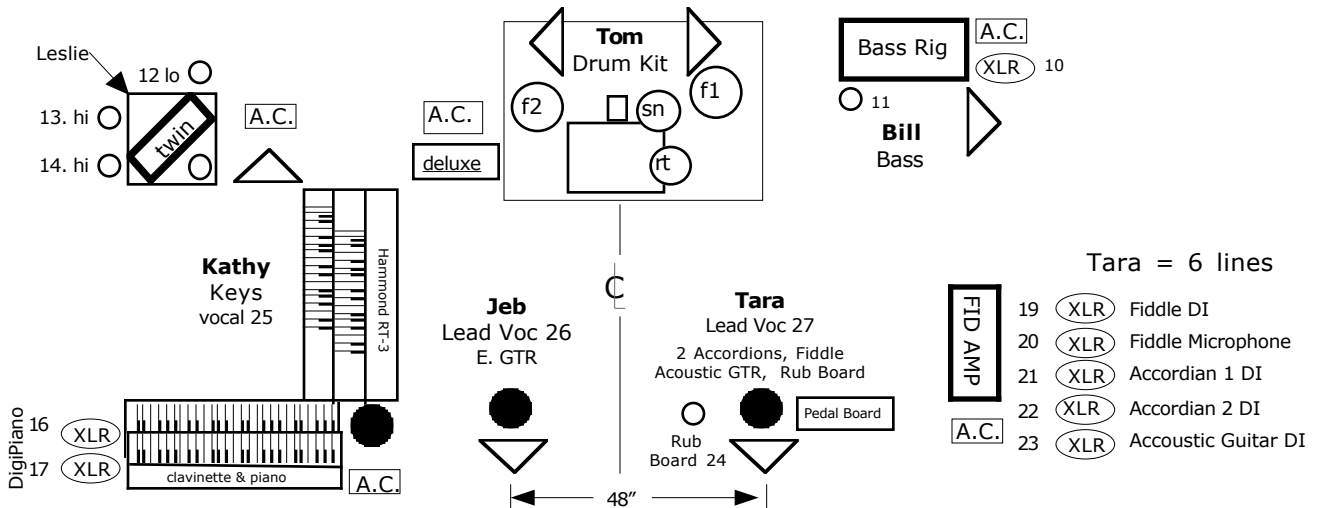

Please Note:

No risers, for any instruments; even at festivals
 There must be a stage side monitor console under all conditions
 We need 6 matching wedges on 5 mixes on stage; + a matching cue wedge

● = Vocal Mic Stand	○ = Instrument Mic Stand
(XLR) = Microphone cable	[D.I.] = Direct Box
▽ = Monitor Wedge	[A.C.] = 120 Volt Quad Box

Outboard Effects Desired:
 2 Lexicon Reverb (any)
 Comps on: Bass & 3 vocals
 Gates on: Kick & 3 toms

Contact the band at: foh@donnathebuffalo.com or tech@donnathebuffalo.com